

# RADIONIC INDUSTRIES, INC.

Customer Part #:	
Vendor:	RADIONIC
R.I. Catalog #:	RCFD-UML-26BL
Start method:	Program Start
Connection type:	Connectors
Input voltage:	120-277V ±10%, 50/60Hz
Lamp Configuration	Series

## Electrical Specifications @120V

Lamp Class	LPS #	Rated Lamp(s) (W)	Min. Start Temp (F)	Ballast Factor	Input Current (A)	Input Power (W)	Power Factor	MAX LCCF	MAX % THD
CFQ26W/G24q	2	26	0	1.00	0.45	53.8	0.99	1.5	15
CFM26W/GX24q	2	26	0	1.00	0.47	56.0	0.99		
CFS21W/GR10q	2	21	0	1.10	0.36	42.5	0.99		
FT18W/2G11	2	18	0	0.93	0.30	35.6	0.99		
FT24W/2G11	2	24	0	0.93	0.41	50.0	0.99		
CFQ26W/G24q	1	26	0	0.98	0.23	27.7	0.99		
CFM26W/GX24q	1	26	0	0.98	0.25	29.3	0.99		
CFM32W/GX24q	1	32	0	1.00	0.26	31.2	0.99		
CFM42W/GX24q	1	42	0	1.00	0.37	44.6	0.99		
CFS21W/GR10q	1	21	0	1.15	0.19	22.8	0.99		
FT18W/2G11	1	18	0	0.98	0.16	18.5	0.99		
FT24W/2G11	1	24	0	0.98	0.22	26.6	0.99		

## Wiring Diagram

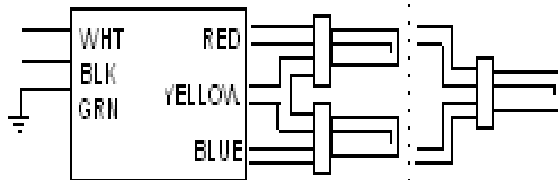

Lead Length (inches)

Black	N/A
White	N/A
Green	N/A
Blue	N/A
Red	N/A
Yellow	N/A

## Enclosure Drawing

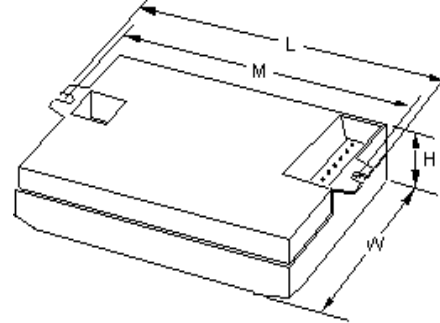

Enclosure Dimension (inches)

Length (L)	Width (W)	Height (H)	Mounting (M)
4.93	2.31	1.13	4.62

## NOTES:

1. Conforms to FCC, part 18, Class B for residential applications.
2. Conforms to ANSI C62.41-1993 for transient protection.
5. Conforms to ANSI C82.11
4. Class P, sound rated A

Safety	UL	CSA	CE	cULus	Other
Control No.				E14926	

These are test results under laboratory conditions. Performance parameters may vary depending on field conditions. Specifications are subject to change without notice. See our complete warranty for details.